



### EG-7006 / NARROW WEB CANTILEVERED SLITTER REWINDER

EG-7006 is a small width machine for secondary slitting rewinding. The unwinding and rewinding are built as cantilevered type for side loading of jumbo and finish rolls. This compact machine is capable to handle the rewind diameter up to 800mm with min. slit width of 20mm as well as for doctoring purpose.

#### MAIN FEATURES

- Integrated unwind with cantilevered design
- Unwind auto. tension control
- Auto edge guider
- Choice of razor or shear cutter
- Trim waste air blower
- PLC with human interface operation

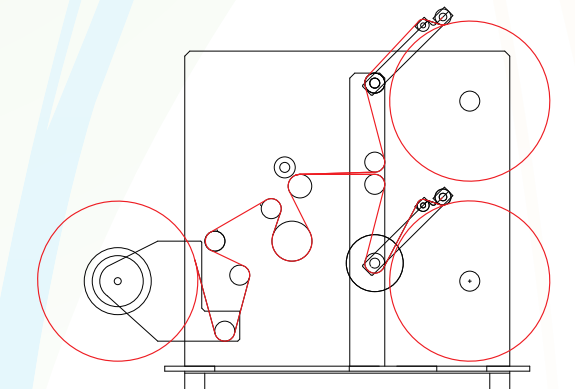
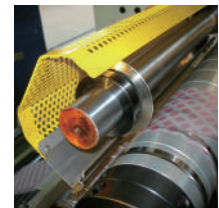
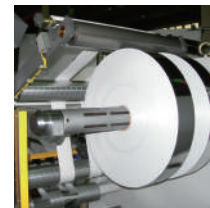

#### TECHNICAL DATA

Roller width	600 / 800 mm
Unwind diameter	450 / 600 / 800 mm
Rewind diameter	450 / 600 / 800 mm
Slit width	20 mm, and up
Mechanical speed	200 / 300 M/min



### EG-7006 | 懸臂式之上下軸中心捲取分條機

適用於各種材料的加工及小寬幅之入料與分切。懸臂式設計，方便入出料。  
滑差捲取軸，亦可當一般氣脹軸使用。接觸壓輪之配合選用，有效控制收捲硬度。

#### 隨機配備

- 與主機一體之懸臂式發送座
- 發送張力自動控制
- 自動對邊追蹤裝置
- 可選配刮刀或上下式圓刀
- 耳料排除裝置
- 彩色觸控(HMI)操作

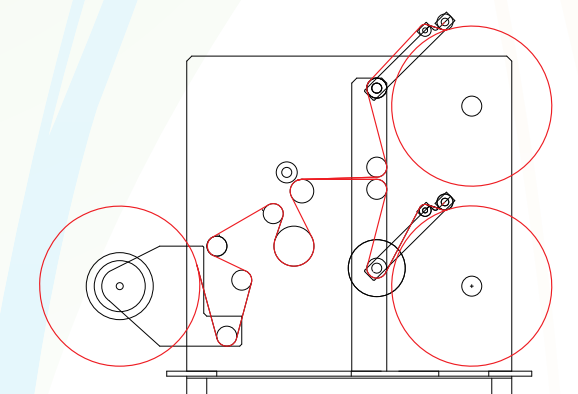

#### 參考規格

輪面寬度	600 / 800 mm
發送外徑	450 / 600 / 800 mm
捲取外徑	450 / 600 / 800 mm
分切寬度	20 mm, 以上可調
分切速度	200 / 300 M/min