



EG-7003A | 上下軸式捲取分條機

為包裝產業普遍使用之系列機種，適用於各種膜類、箔類的加工。特殊設計之滑差捲取軸，亦可當一般氣脹軸使用。接觸壓輪之配合選用，有效控制收捲硬度。成品卷銜接裝置，手推卸出成品。

隨機配備

- 無軸式發送座
- 發送張力自動控制
- 自動對邊追蹤裝置
- 可選配刮刀或上下式圓刀
- 耳料排除裝置
- 成品卷銜接裝置
- 彩色觸控(HMI)操作

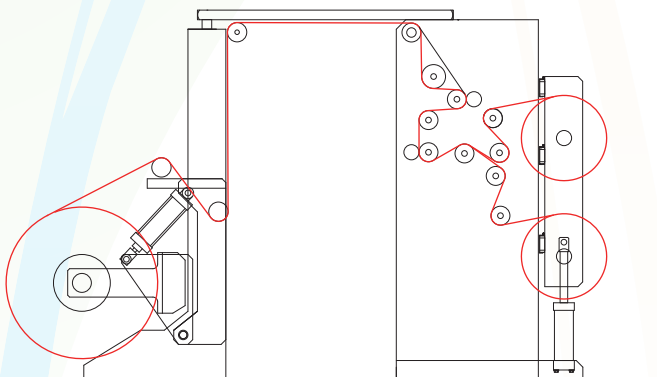
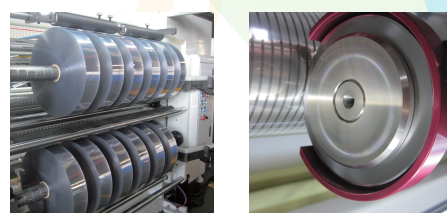

參考規格

輪面寬度	600 ~ 1700 mm
發送外徑	800 ~ 1200 mm
捲取外徑	450 mm
分切寬度	50 mm, 以上可調
分切速度	300 M/min



EG-7003A / DUPLEX CENTRE SLITTER REWINDER

EG-7003A is the popular model for flexible packaging industry, the machine equips with free moving shaftless unwind stand and user friendly automation such as auto tension control, auto edge guide device and PLC control to make sure one operator can simply look after the production to reduce cost and increase productivities.

MAIN FEATURES

- Shaftless unwind stand
- Unwind auto. tension control
- Auto. edge guider
- Choice of razor or shear cutter
- Integrated trim winder
- Bearing mounted fork type unloading device
- PLC with human interface operation.

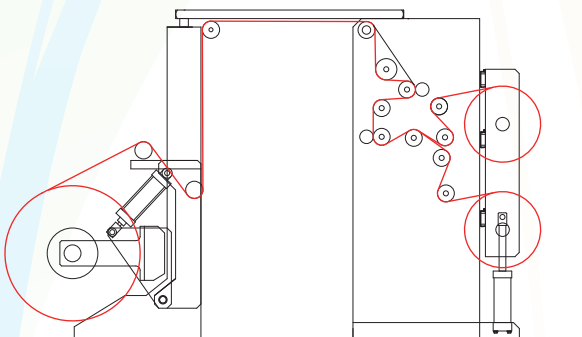
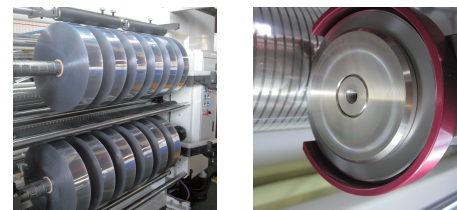

TECHNICAL DATA

Roller width	600 ~ 1700 mm
Unwind diameter	800 ~ 1200 mm
Rewind diameter	450 mm
Slit width	50 mm, and up
Mechanical speed	300 M/min